



**TAKEUCHI**

**TB2150**

Crawler excavator with boom offset

With the standard rear excavator **TB2150**, with swivel frame and side offset, digging parallel to a wall or masonry is easily possible. The TB2150 is a 16-tonne excavator and the largest in the TAKEUCHI family, but it works like a miniexcavator.



- › 1<sup>st</sup> hydraulic circuit, with proportional control with 224 l/min High Flow
- › Available with rubber or steel crawlers. Crawlers can be interchanged at any time.
- › LED worklights for optimum illumination of working area



**For three hours, two days or a whole year** - if you need it for your construction site, you can **buy and rent** your TB2150 from us.

[www.huppenkothen.com](http://www.huppenkothen.com)



# Huppenkothen added-value equipment:

**There is additional equipment that everyone wants.**

You therefore get all as standard from Huppenkothen. This makes your excavator more effective, faster and more comfortable.

**Put simply - added value.**

## HYDRAULICS

4 hydraulic auxiliary circuits, 3 of which have proportional control

Flow rates and pressure adjustable on the display

1<sup>st</sup> circuit: 3 memories, 2<sup>nd</sup>/4<sup>th</sup> circuit: 1 memory

1<sup>st</sup> hydraulic auxiliary circuit, with proportional control - max. 224 l/min

2<sup>nd</sup> hydraulic auxiliary circuit, with proportional control - max. 54,8 l/min

3<sup>rd</sup> hydraulic auxiliary circuit, for hydraulic quick change plate HUPPlate H

4<sup>th</sup> hydraulic auxiliary circuit, with proportional control - max. 54,8 l/min

Detend Mode - breaker line continuous operation

Auto-Tank - depressurised return flow for breaker operation

Automatic pressure relief of control circuits when quick change plate is actuated

Hydraulic tank ventilation

Pilot-opened load-holding valve on boom cylinder and arm cylinder

End position damping at boom, arm and swing cylinder



Exclusive additional equipment



Powerful



Spacious and comfortable operator cabin

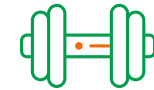

Adjustable powerhouse

## CAB WITH COMFORT EQUIPMENT

Comfort cabin including roof guard ROPS (ISO12117-2) / OPG (ISO10262 Level II)

7" multifunction color display

Automatic temperature controlled air conditioning with 4 outlet nozzles and air-conditioned cup holder

Heating and radio with AUX & USB

Air suspension comfort seat with seat heating

HFM (HUPPIFleetManagement) - telematics system with 2 year term of use, extended for additional charge

ECO mode - to increase economic efficiency

Automatic idle speed control - optimised fuel consumption

Sun shield

Rain guard

## TECHNICAL AND SAFETY EQUIPMENT

Double air filter - additional protection for the engine

Boom with 2 lifting cylinders

Spring-loaded accumulator on parking brake

Spring-loaded accumulator on slew brake

Electric refuelling pump

Pressure accumulator for pressure relief of hydraulic circuits and emergency boom lowering

Storage compartment with on-board toolkit

Acoustic overload warning device (EN474-5)

Travel alarm

Rear view camera - for more safety

LED worklights- 2 x cab at front, 1 x cab at rear, 1 x engine hood at front, 1 x boom

Socket on cab roof for rotary beacon

Optional additional equipment and services



### HUPPLub

Huppenkothen central lubrication system to ensure everything runs even more smoothly.

/

### HUPPView

Bucket position control system for precise work.

/

### HUPPLevel

Automated levelling and planing.

/

### HUPPIWarranty

Extended premium warranty package with all-round protection.

/

### HUPPIFleetManagement

An eye on every machine at all times with fleet management. First 2 years included in purchase price.



TECHNICAL DATA	
Engine	DEUTZ TCD3.6L4 4-cylinder Commonrail diesel engine, turbocharger, 85 kW @ 2.200 rpm (ISO14396) Stage V emission level with DPF, SCR and DOC
Dimensions (mm)	8.165 x 2.500 x 2.960
Digging depth (mm)	5.195
Reach (mm)	8.520
Arm length (mm)	2.320
Tail swing radius (mm)	2.000

MAIN DIMENSIONS	
Service weight* (kg)	15.850
Total width (mm)	2.500
Overall height (mm)	2.960
Transport length - dozer blade at the rear (mm)	8.165
Boom swing angle l / r (°)	77 / 53

\* Machine weight + SWPL + PL + medium size bucket + half a tank of diesel

CHASSIS	
Tracks	Rubber
Track width (mm)	500
Ground contact (mm)	2.895
Ground pressure (kg/cm <sup>2</sup> )	0,471
Ground clearance (mm)	475
Dozer blade dimensions (mm)	2.490 x 550

WORK PERFORMANCE	
Travel speed (km/h)	3,1 (1 <sup>st</sup> gear) / 5,5 (2 <sup>nd</sup> gear)
Slew speed (rpm)	10,8
Gradeability (degrees / %)	35 / 70
Digging force bucket (kN)	96,3
Digging force arm (kN)	59,8

HYDRAULIC SYSTEM	
Hydraulic pumps	2 x variable axial piston pump + 2 x gear pump
Pump pressure (bar)	343 x 343 x 236 x 39
Flow rate (l/min)	112 x 112 x 54,8 x 20
Hydraulic tank (l)	107 (Tank) / 160 (total)
Slew motor type	Axial piston motor, rigid
Travel motor type	Axial piston motor, variable

AUXILIARY CONTROL CIRCUITS	
1 <sup>st</sup> hydraulic breaker control circuit (l/min)	224
3 memories for flow rates and pressure	
2 <sup>nd</sup> /4 <sup>th</sup> Powertilt/grab control circuit (l/min)	54,8
1 memory for flow rates and pressure	

- 01 Sound-damped, low-vibration comfort cab with air suspension comfort seat with seat heating.
- 02 Robust boom swing assy with specially protected hose guide and hydraulic boom swing; lifting, arm and swing cylinder with end position damping.
- 03 Generous maintenance hatches for service-friendly access to hydraulic and fuel maintenance components.
- 04 Optimally arranged controls with large, clear and user-friendly display with rear view camera overlay.
- 05 4 hydraulic circuits as standard, 3 of which have proportional control; adjustable flow rates and pressure.
- 06 Generous maintenance hatch guarantees optimum accessibility to the battery and radiator cleaning.

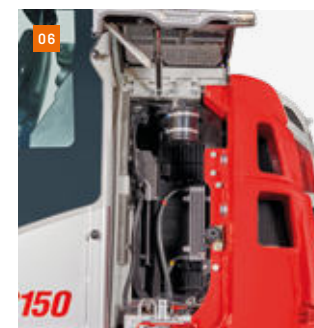
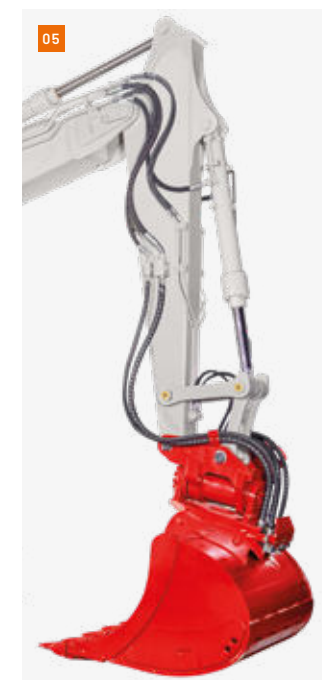
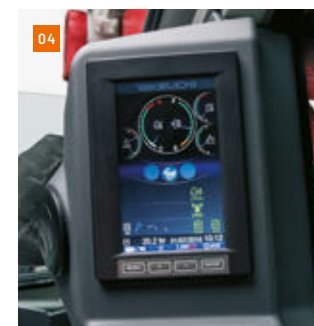
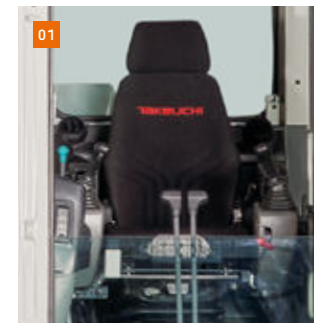

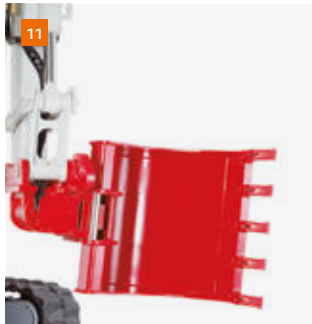
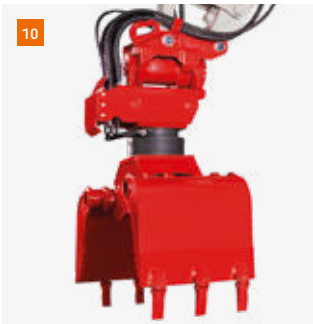
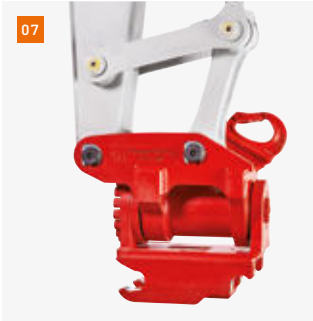

07 HUPPTilt R tilt-rotator with HUPPPlate H

08 HUPPQuick system: Hydraulic connections are connected automatically during the quick coupling process.

09 HUPPBREAK hydraulic breaker 903 with HUPPQuick

10 HUPPGrip universal grabber with HUPPTilt and HUPPQuick quick coupling system

11 HUPPTilt with HUPPPlate H, digging bucket mounted as high bucket

12 Concrete buster - Epiroc CB950

13 Add-on compactor - Ammann APA75/74

14 Drum Cutter - Erkat ER600

## Lifting load (kg)

Forward (upper dozer blade)

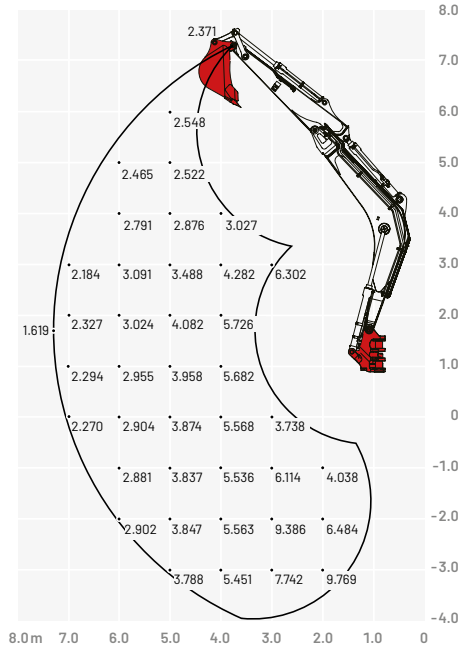

The loads in the diagram are within 87% of the hydraulic lifting load and within 75% of the tipping load.

## Dimensions (mm)

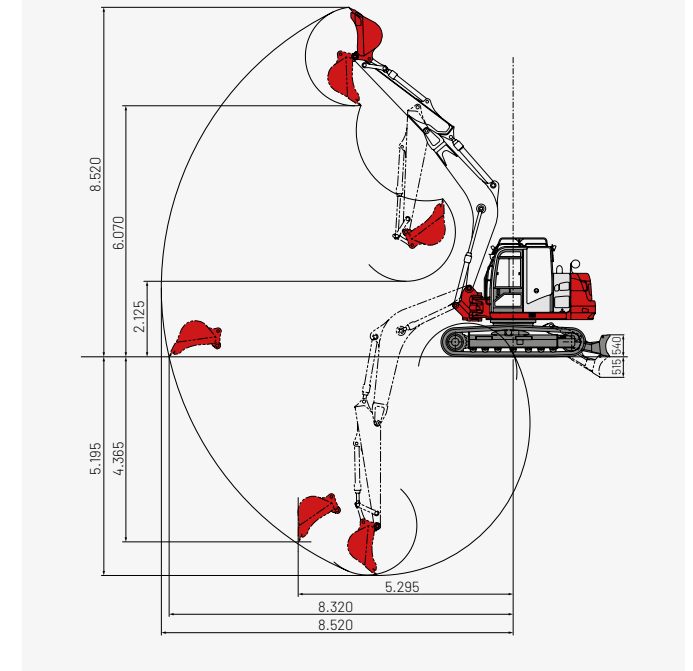
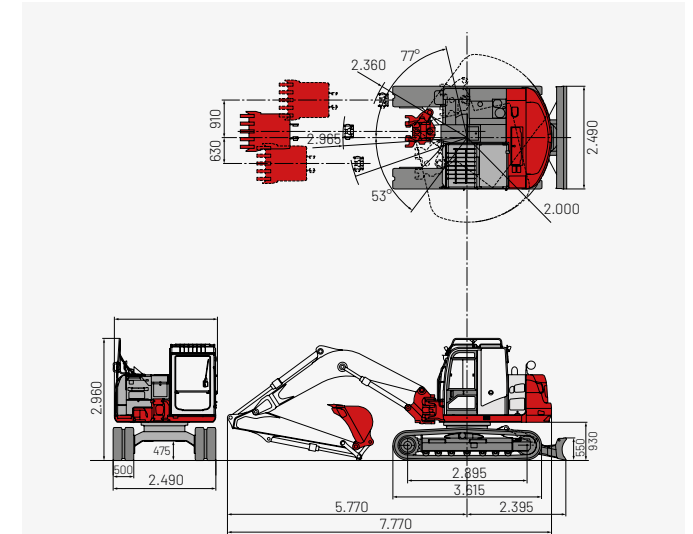

More accessories at  
[huppenkothen.com/  
 excavator-accessories](http://huppenkothen.com/excavator-accessories)

## Huppenkothen – your construction site, your partner, your success!

If you're looking to buy or rent a construction machine, if quality is important to you and you have no time to lose, then you've come to the right place with Huppenkothen. We provide all you need for your construction site. If you have any questions:

**We are always available.**

**41**  
Locations

**350**  
Employees

**4.500+**  
Machines

**100 %**  
Service

### AUSTRIA (AT)

/

#### Huppenkothen GmbH

Bundesstraße 117 / 6923 Lauterach  
T +43 50 663 400 / F +43 5574 778 24  
info@huppenkothen.com

### SWITZERLAND (CH)

/

#### Huppenkothen Baumaschinen AG

Hinterwiden / 9245 Oberbüren  
T +41 71 944 18 11 / F +41 71 944 18 69  
oberbueren@huppenkothen.com

### SOUTH-TIROL (IT)

/

#### Huppenkothen GmbH / SRL

Peter-Anich-Straße 1 / 39011 Lana (BZ)  
T +39 0473 491 170 / F +39 0473 491 171  
lana@huppenkothen.com

### SLOVENIA (SVN)

/

#### Huppenkothen d.o.o.

Slovenčeva ulica 97, 1113 Ljubljana  
T +386 15 300 333 / F +386 15 300 344  
ljubljana@huppenkothen.com

The complete  
Huppenkothen  
product range

