

TAKEUCHI

TL-Series

Compact track loaders

TL8R-2 | TL10V-2 | TL12V-2 | TL12R-2



Takeuchi's **compact track loaders** score with their **stability, high payload and manoeuvrability, as they can turn in the smallest of spaces.** With your TL, you won't be put off by bad weather or difficult or muddy ground conditions. Thanks to the rubber tracks, our track loaders have low ground pressure and good off-road mobility.



- › Auxiliary hydraulic circuit with High Flow
- › Air conditioning, heater and radio for optimal driver comfort
- › LED worklights for optimum illumination of working area
- › Tilttable cabin for easy maintenance and convenient access to the engine
- › Depending on model with radial or vertical lift



For three hours,
two days or a whole year -
if you need it for your construction site,
you can **buy and rent** your compact
track loader from us.

www.huppenkothén.com



Huppenkothen added-value equipment:

There is additional equipment that everyone wants.

You therefore get all as standard from Huppenkothen. This makes your compact track loader more effective, faster and more comfortable.

Put simply - added value.



Exclusive additional equipment



Powerful



Spacious and comfortable operator cabin

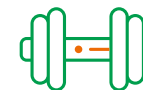

Agile powerhouse

SCOPE OF DELIVERY

Rubber crawlers 400 / 450 mm

Cabin ROPS / FOPS Level I

Air conditioning, heater and radio

Mechanically suspended seat with dead man's switch

Pelvic safety belt

Joystick control

Accelerator pedal in addition to the joystick

Detend Mode - auxiliary line continuous operation

Double air filter

Fully hydrostatic drive

Air breather for hydraulic tank

ECO-Mode, active power control management system

5,7" multifunction color display

Rear view camera

Travel alarm

Tilt-up operator's station

Rear bumper integrated into the frame

LED work lights front and rear

Loading bucket without teeth - width: 1680 / 1880 / 2000 mm

HUPPENKOTHEN PACKAGE

HFM (HUPPIFleetManagement) - telematic system with a 2 years service license - period extension by surcharge

14-pin electrical connection for attachments - controlled via joystick

Hydraulic quick-change device (universal)

Manual parking brake

Cruise control - Setting of a constant driving speed in 20 stages (from 0.15 km/h) for attachments such as asphalt milling machines (only TL8R-2)

Optional additional equipment and services*



HUPPIWarranty*

Extended premium warranty package with all-round protection.

/ **HUPPIFleetManagement***

An eye on every machine at all times with fleet management. First 2 years included in purchase price.

TECHNICAL DATA	TAKEUCHI TL8R-2 Compact track loader with radial lift (approx. 4.165 kg)	TAKEUCHI TL10V-2 Compact track loader with vertical lift (approx. 4.660 kg)	TAKEUCHI TL12R-2 Compact track loader with radial lift (approx. 5.710 kg)	TAKEUCHI TL12V-2 Compact track loader with vertical lift (approx. 5.985 kg)
Engine	KUBOTA V3307-CR-TE5B diesel engine 54,6 kW @ 2.600 rpm (ISO 14396) Stage V emission level with DPF and DOC	Kubota V3307-CR-TE5B diesel engine 54,6 kW @ 2.600 rpm (ISO 14396) Stage V emission level with DPF and DOC	Kubota V3800-CR-TIE5B diesel engine 81,8 kW @ 2.400 rpm (ISO 14396) Stage V emission level with DPF, DOC and SCR	Kubota V3800-CR-TIE5B diesel engine 81,8 kW @ 2.400 rpm (ISO 14396) Stage V emission level with DPF, DOC and SCR
Dimensions (mm)	3.485 x 1.680 x 2.230 with loading bucket	3.680 x 1.880 x 2.270 with loading bucket	4.045 x 2.030 x 2.330 with loading bucket	4.045 x 2.030 x 2.330 with loading bucket
Travel speed (km/h)	1 st gear 7,5 / 2 nd gear 11,2	1 st gear 7,7 / 2 nd gear 11,3	1 st gear 8,1 / 2 nd gear 11,8	1 st gear 8,1 / 2 nd gear 11,8
Hydraulic service port for attachments	High Flow 128 l/min / 210 bar	High Flow 124 l/min / 210 bar	High Flow 153 l/min / 240 bar	High Flow 153 l/min / 240 bar
Turning radius outside (mm)	2.190	2.350	2.555	2.505
Max. discharge height (mm)	2.420	2.435	2.400	2.460
Payload (kg)	960	1.145	1.350	1.865
Tipping load (kg)	2.740	3.270	3.915	5.325
Ground pressure (kg/cm ²)	0,320	0,359	0,327	0,343



Radial or vertical lift: the differences



Radial lift

- » Maximum reach at loading area height
- » Ideal for backfilling or dumping over walls
- » Highest performance for heavy digging
- » Better performance for excavating, digging, levelling and earthworks



Vertical lift

- » Greater reach at full lift height
- » Higher lifting capacity as the load stays closer to the machine
- » Ideal for stacking or loading at height
- » Optimum visibility to the left and right thanks to low arm position



05

- 01 The spacious and comfortable cab interior enables productive and fatigue-free work.
- 02 The auxiliary control circuit with high flow and the 14-pin auxiliary connector allow the machine to be used with a wide range of attachments.

- 03 Two planetary drives ensure optimum travel speed and provide sufficient power for working with heavy attachments.

- 04 The tilting cab allows easy access to the engine and main hydraulic components.

- 05 The hinged rear section guarantees optimal accessibility for radiator cleaning and diesel engine maintenance.

- 06 Clear multifunction display with rear view camera overlay.



06

TL8R-2 Dimensions (mm)

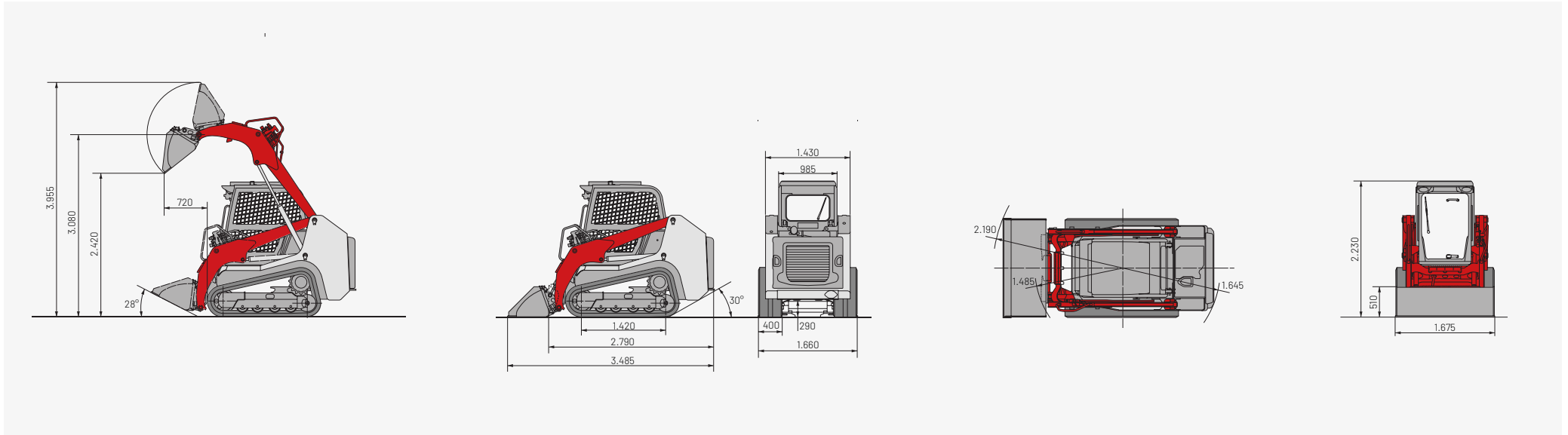

TL10V-2 Dimensions (mm)

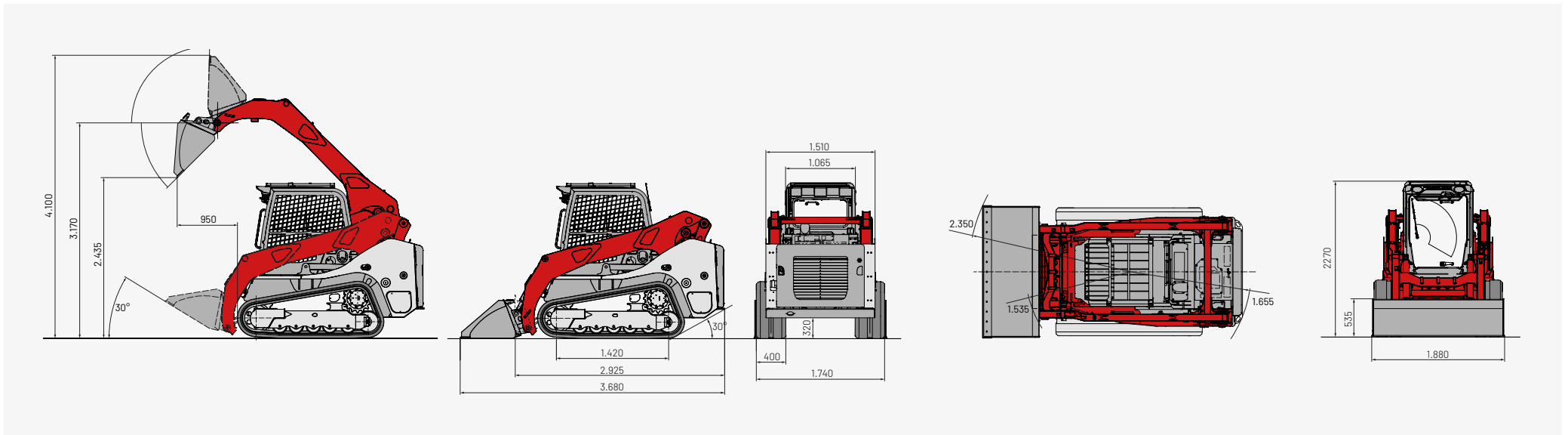

TL12R-2 Dimensions (mm)

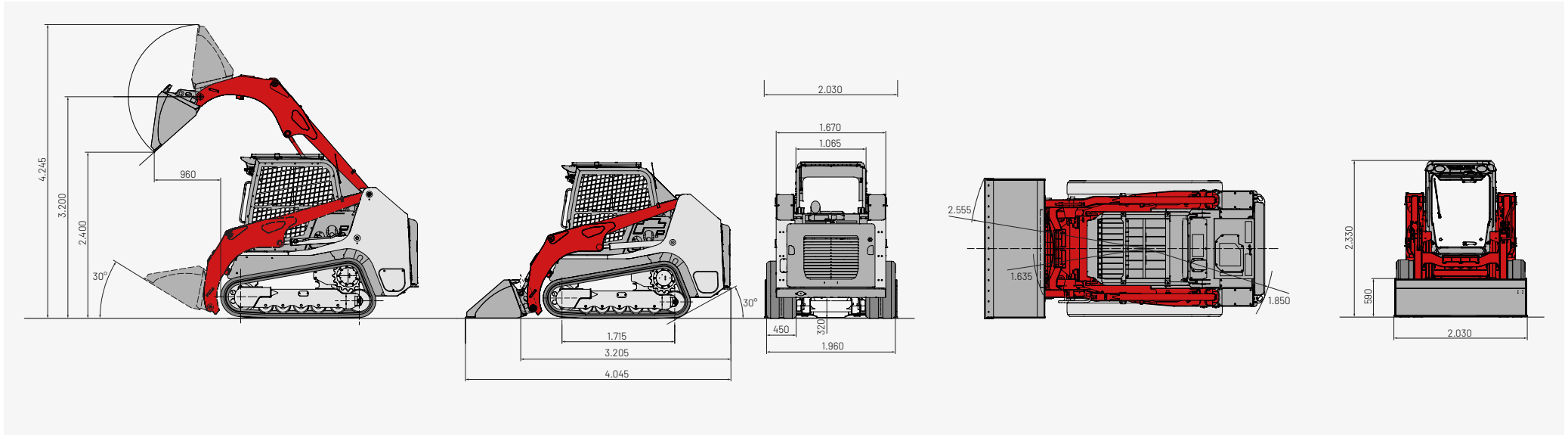

TL12V-2 Dimensions (mm)

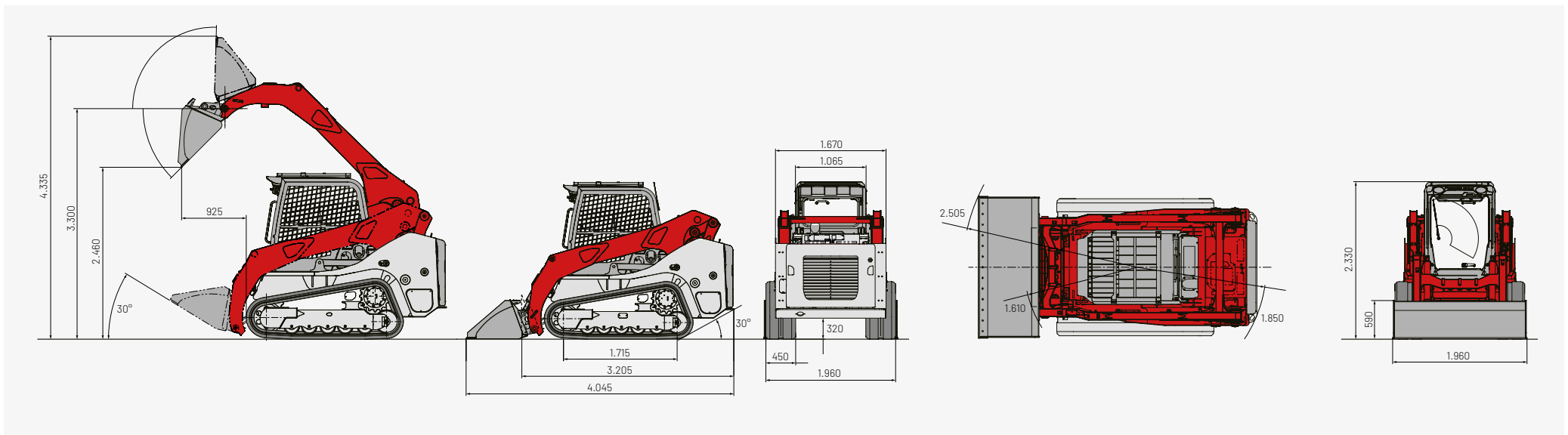

Huppenkothen – your construction site, your partner, your success!

If you're looking to buy or rent a construction machine, if quality is important to you and you have no time to lose, then you've come to the right place with Huppenkothen. We provide all you need for your construction site. If you have any questions:

We are always available.

41
Locations

350
Employees

4.500+
Machines

100 %
Service

AUSTRIA (AT)

/
Huppenkothen GmbH
Bundesstraße 117 / 6923 Lauterach
T +43 5574 785 30 / F +43 5574 778 24
info@huppenkothen.com

SWITZERLAND (CH)

/
Huppenkothen Baumaschinen AG
Hinterwiden / 9245 Oberbüren
T +41 71 944 18 11 / F +41 71 944 18 69
oberbueren@huppenkothen.com

SOUTH-TIROL (IT)

/
Huppenkothen GmbH / SRL
Peter-Anich-Straße 1 / 39011 Lana (BZ)
T +39 0473 491 170 / F +39 0473 491 171
lana@huppenkothen.com

SLOVENIA (SVN)

/
Huppenkothen d.o.o.
Slovenčeva ulica 97, 1113 Ljubljana
T +386 15 300 333 / F +386 15 300 344
ljubljana@huppenkothen.com

The complete
Huppenkothen
product range

